

# TENTATIVE MAP PCS-12-04 OTAY RANCH VILLAGE 2 R-15b & R-31 CITY OF CHULA VISTA, CALIFORNIA

## GENERAL NOTES

- GROSS SUBDIVISION AREA: 1.83 AC.
- TOTAL NUMBER OF EXISTING LOTS: 2
- TOTAL NUMBER OF PROPOSED LOTS: 7
- TOTAL NUMBER OF PROPOSED UNITS: 31 (6 SF, 25 MF)
- ASSESSOR PARCEL NUMBER: 644-310-08
- EXISTING/PROPOSED GENERAL PLAN DESIGNATION: LMV
- EXISTING ZONING: OPI
- PROPOSED ZONING: SF2 (R-31) & SF4 (R-15b)
- DENSITY LOT "E": 8.2 DU/AC (6 UNITS/0.73 AC)
- DENSITY LOT "F": 22.7 DU/AC (25 UNITS/1.10 AC)
- PRESENT LAND USE: VACANT
- PROPOSED LAND USE: SINGLE FAMILY RESIDENTIAL (R-15b) & MULTI-FAMILY (R-31)
- THIS MAP SUBSTANTIALLY CONFORMS TO THE CITY OF CHULA VISTA GENERAL PLAN, THE OTAY RANCH GENERAL DEVELOPMENT PLAN AND THE OTAY RANCH VILLAGE 2 SECTIONAL PLANNING AREA PLAN.
- WATER SYSTEM TO BE INSTALLED IN ACCORDANCE WITH THE STANDARDS OF THE OTAY WATER DISTRICT AND SHALL BE MAINTAINED AND OPERATED BY THE DISTRICT.
- SPECIFIC METHODS OF HANDLING STORM WATER ARE SUBJECT TO DETAILED APPROVAL BY THE CITY DEVELOPMENT SERVICES DEPARTMENT AT THE TIME OF SUBMISSION OF IMPROVEMENT AND GRADING PLANS. DESIGN SHALL BE ACCOMPLISHED ON THE BASIS OF THE REQUIREMENTS OF THE SUBDIVISION MANUAL. DRAINAGE EASEMENTS SHALL BE PROVIDED AS REQUIRED BY THE CITY DEVELOPMENT SERVICES DEPARTMENT.
- SANITARY SEWER TO BE PROVIDED AND CONNECTED TO CITY OF CHULA VISTA SEWERS. SEWER MAINS ARE 8" MINIMUM P.V.C. UNLESS SHOWN OTHERWISE.
- EVIDENCE SHALL BE PROVIDED OF HAVING OBTAINED GRADING RIGHTS UPON ADJACENT PROPERTY WHERE REQUIRED DURING FINAL ENGINEERING.
- STREET TREE DEPOSITS SHALL BE PAID IN ACCORDANCE WITH ORDINANCE NUMBER 1369 AND NO. 1687 OF THE CITY OF CHULA VISTA.
- UTILITIES SHALL BE UNDERGROUND AND EASEMENTS PROVIDED AS NECESSARY.
- SUBDIVISION TO PROVIDE AND INSTALL APPROVED STREET LIGHT STANDARDS AND FIXTURES IN THE TYPE AND NUMBER APPROVED BY THE CITY DEVELOPMENT SERVICES DEPARTMENT FOR PUBLIC RIGHT-OF-WAY.
- SLOPE PLANTING SHALL BE IN ACCORDANCE WITH THE CITY OF CHULA VISTA LANDSCAPE MANUAL, AND/OR THE OTAY RANCH VILLAGE DESIGN PLAN.
- GRADING SHALL BE CONSTRUCTED IN ACCORDANCE WITH ORDINANCE NO. 1797 (AS AMENDED BY ORDINANCE NO. 1877) OF THE CITY OF CHULA VISTA.
- ALL WORK IN THE PUBLIC RIGHT-OF-WAY SHALL BE DONE IN ACCORDANCE WITH THE STANDARD SPECIFICATIONS FOR PUBLIC WORKS CONSTRUCTION, THE SAN DIEGO AREA REGIONAL STANDARD DRAWINGS AND THE DESIGN AND CONSTRUCTION STANDARDS OF THE CITY OF CHULA VISTA.
- FIRE HYDRANTS TO BE INSTALLED IN ACCORDANCE WITH THE CITY OF CHULA VISTA DESIGN STANDARD NO. 8. FIRE HYDRANTS AS SHOWN ON THIS MAP SHALL BE USED AS A GUIDE ONLY.
- ONE FOOT CONTROL LOTS TO BE GRANTED TO THE CITY OF CHULA VISTA BY SEPARATE DEED WHERE DETERMINED NECESSARY BY THE CITY DEVELOPMENT SERVICES DEPARTMENT.
- GRADING AND MODEL HOMES MAY BE BUILT PRIOR TO FINAL MAP RECORDATION.
- GRADING SHOWN HEREON IS PRELIMINARY AND SUBJECT TO MODIFICATION IN FINAL DESIGN SUBJECT TO SUBSTANTIAL CONFORMANCE APPROVAL BY THE CITY OF CHULA VISTA ENGINEERING DEPARTMENT.
- THIS PROJECT IS A MULTIPLE UNIT (NEIGHBORHOOD) SUBDIVISION. MULTIPLE FINAL MAPS MAY BE FILED IN ACCORDANCE WITH THE PROVISIONS OF ARTICLE 4 OF SECTION 66456.1 OF THE SUBDIVISION MAP ACT.
- FINAL MAPS MAY BE RECORDED FOR THE PURPOSE OF SUBDIVIDING VILLAGES OR PORTIONS THEREOF INTO UNIMPROVED NEIGHBORHOODS WITH LEGAL ACCESS WITH THE INTENT OF TRANSFERRING TITLE TO MERCHANT BUILDERS.
- STORM DRAIN AND SEWER SHOWN HEREON IS PRELIMINARY AND SUBJECT TO MODIFICATION IN FINAL DESIGN.
- TEMPORARY AND PERMANENT STRUCTURAL BEST MANAGEMENT PRACTICES WILL BE INCORPORATED IN THE DESIGN AND IMPLEMENTATION OF THE DEVELOPMENT.
- PRELIMINARY GEOTECHNICAL REPORT PREPARED BY: GEODON INCORPORATED DATED AUGUST 18, 2003.
- SOURCE OF TOPOGRAPHY: ROBERT J. LINS
- REFER TO THE "WATER QUALITY TECHNICAL REPORT" PREPARED BY HUNSAKER & ASSOCIATES FOR COMPLIANCE WITH THE REGIONAL WATER QUALITY CONTROL BOARD JURISDICTIONAL PERMIT TEMPORARY TURNAROUNDS SHALL BE PROVIDED AT ALL DEAD END STREETS SURVIVING FINAL ENGINEERING AS REQUIRED BY THE CITY DEVELOPMENT SERVICES DEPARTMENT.
- OFFSITE IMPROVEMENTS MAY BE REQUIRED IN ACCORDANCE WITH THE OTAY RANCH VILLAGE 2 PUBLIC FACILITIES FINANCE PLAN AND SUPPLEMENTAL PUBLIC FACILITIES FINANCE PLAN.

NEIGHBORHOOD R-15b	
LOT #	LOT AREA
1	6,044
2	5,981
3	6,037
4	6,083
5	5,828
6	5,270
RES SUBTOTAL SF	35,223
RES SUBTOTAL AC	0.8
MAX	6,083
MIN	5,270
RES AVG LOT SIZE	5,871
TOTAL SF	35,223
TOTAL AC	0.81

## LEGAL DESCRIPTION

**PARCEL A**  
ALL OF LOTS "E" & "F" OF CHULA VISTA TRACT NO. 06-05 OTAY RANCH VILLAGE 2 NEIGHBORHOOD R-15a, IN THE CITY OF CHULA VISTA, COUNTY OF SAN DIEGO, STATE OF CALIFORNIA ACCORDING TO MAP THEREOF NO. 15862 FILED IN THE OFFICE OF THE COUNTY RECORDER OF SAID COUNTY APRIL 4, 2012.

**PARCEL B**  
THAT PORTION OF THE SAN DIEGO PIPELINE PROPERTY GRANTED TO THE CITY OF SAN DIEGO PER DEED RECORDED JUNE 24, 1912 IN BOOK 570, PAGE 113 OF DEEDS.

## EASEMENT NOTES

INDICATES AN EASEMENT FOR WATER PIPE LINES AND TRENCH AND EXCAVATION SLOPES AND WASTING OF EXCESS EXCAVATED MATERIALS GRANTED TO THE CITY OF SAN DIEGO PER DOCUMENT RECORDED JULY 14, 1923 IN BOOK 937, PAGE 463 OF DEEDS.

## OWNER/SUBDIVIDER

OTAY RANCH VILLAGE 11-PC-15, LLC  
A DELAWARE LIMITED LIABILITY COMPANY  
610 WEST ASH, SUITE 1500  
SAN DIEGO, CA. 92101  
(619) 234-4050

SHAWN BALDWIN  
**CIVIL ENGINEER**

HUNSAKER & ASSOCIATES, SAN DIEGO, INC.  
9707 MAPLES STREET  
SAN DIEGO, CA 92121  
(658) 558-4500

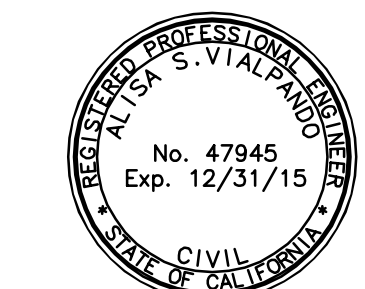

Alisa S. Vialpando 10/21/14  
ALISA S. VIALPANDO, R.C.E. 47945 DATE  
MY REGISTRATION EXPIRES ON 12/31/15

## CONDOMINIUM NOTE

THIS IS A MAP OF A CONDOMINIUM PROJECT AS DEFINED IN SECTION 4125 OF THE CIVIL CODE OF THE STATE OF CALIFORNIA AND IS FILED PURSUANT TO THE SUBDIVISION MAP ACT. PLANNING NEIGHBORHOODS INCLUDED WITHIN THE CONDOMINIUM PROJECTS DESIGNATION ARE R-10a AND R-10b. THE MAXIMUM NUMBER OF DWELLING UNITS IS 25 TOTAL (R-31 25 UNITS).

## EARTHWORK QUANTITIES

OUT: 2,240 C.Y. FILL: 2,240 C.Y.

## PUBLIC UTILITIES

SEWER CITY OF CHULA VISTA  
WATER OTAY WATER DISTRICT  
STORM DRAIN CITY OF CHULA VISTA  
TELEPHONE AT&T  
GAS AND ELECTRIC SOGRE  
CABLE T.V. COX COMMUNICATIONS  
POLICE & FIRE CITY OF CHULA VISTA  
SCHOOLS CHULA VISTA ELEMENTARY SCHOOL DISTRICT  
SWEETWATER UNION HIGH SCHOOL DISTRICT

## PROJECT WAIVERS

- CORNER SIGHT DISTANCE REQUIREMENTS SHALL BE PER CALTRANS STANDARDS. A WAIVER IS REQUESTED TO ELIMINATE THE 45' CORNER SIGHT DISTANCE AND 3' SETBACK TO ALLOW THE ARCHITECTURE TO MOVE TOWARDS THE STREET AS APPROVED PER THE SPA DOCUMENT.
- STREET WAIVERS  
  - (A) PARKWAY RESIDENTIAL**  
- ADD STREET PARKING ON BOTH SIDES
- INTERSECTIONS THAT ARE WITHIN HORIZONTAL CURVES OR WITHIN 100-FOOT TANGENTS OF HORIZONTAL CURVES.
- TO ALLOW ALL INTERNAL STREETS TO BE DESIGNED FOR A 25 MPH DESIGN SPEED.
- TO ALLOW TYPICAL LOT DRAINAGE TO BE REDUCED FROM 5% AWAY FROM HOUSE TO 2% AWAY FROM HOUSE. ALLOW LOT DRAINAGE SWALE GRADE TO BE REDUCED FROM 2% TO 1%.

## LEGEND

- SUBDIVISION BOUNDARY
- EXISTING TOPO CONTOUR
- LOT LINE
- PAD ELEVATION
- RESIDENTIAL LOT
- SLOPE (2:1 MAX)
- PERCENT OF GRADE
- STREET ELEVATION
- SEWER MAIN (8")
- SEWER INVERT ELEVATION
- WATER MAIN (8")
- FIRE HYDRANT
- STORM DRAIN (18")
- STREET LIGHT
- EASEMENT LINE
- UNLESS SHOWN OTHERWISE

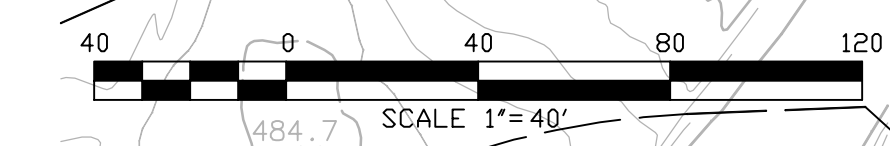
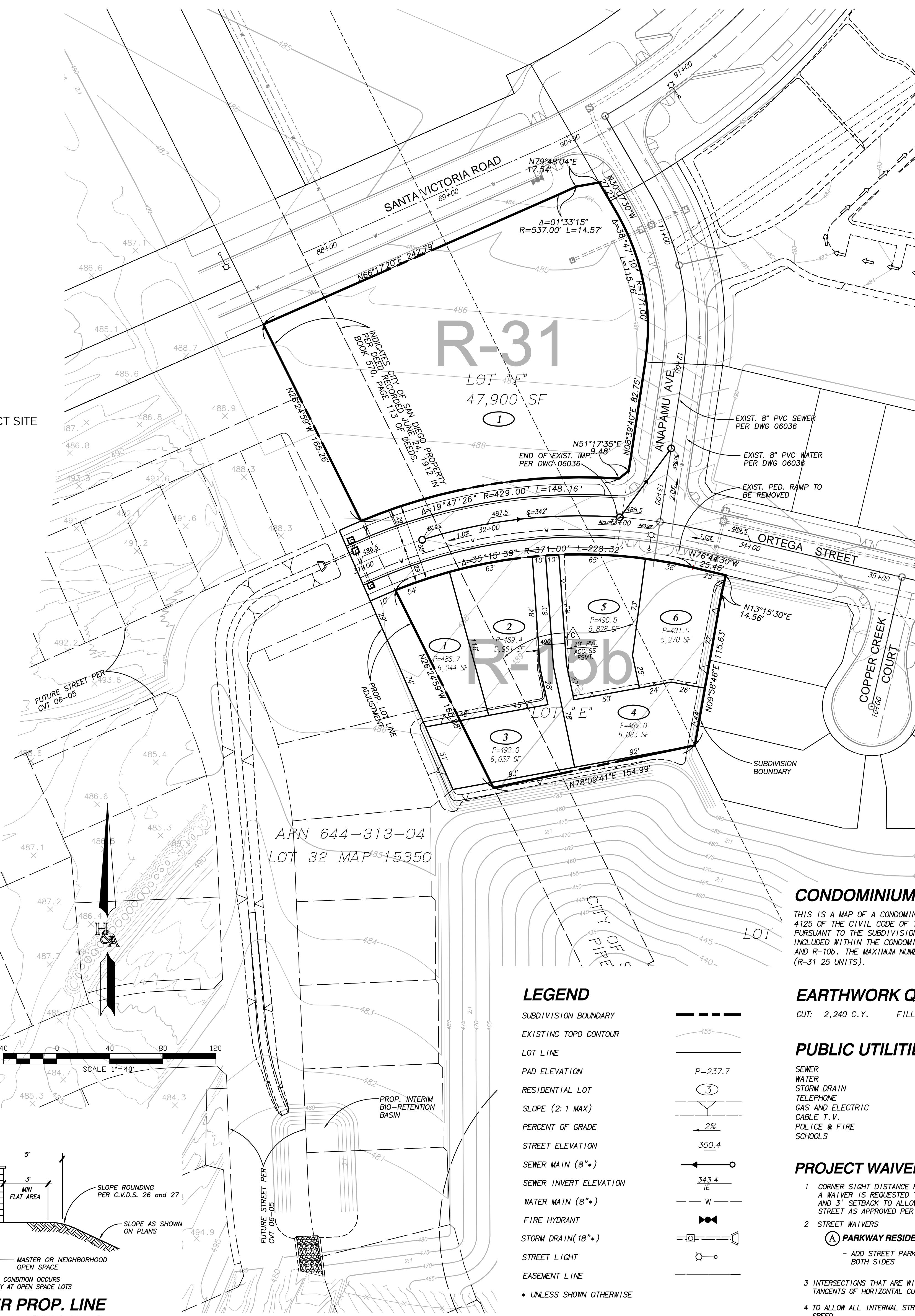
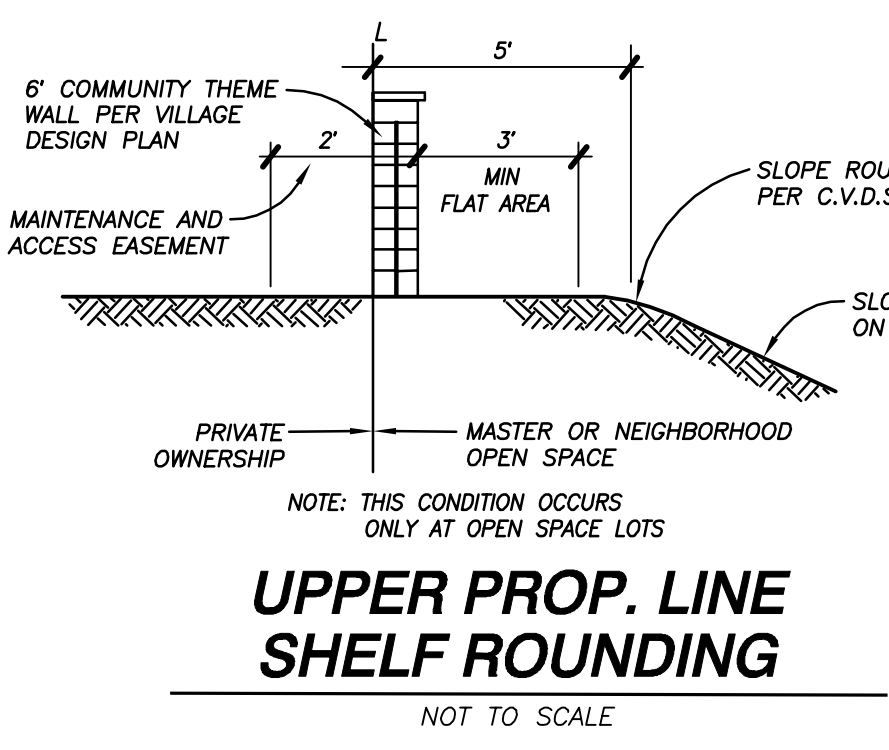
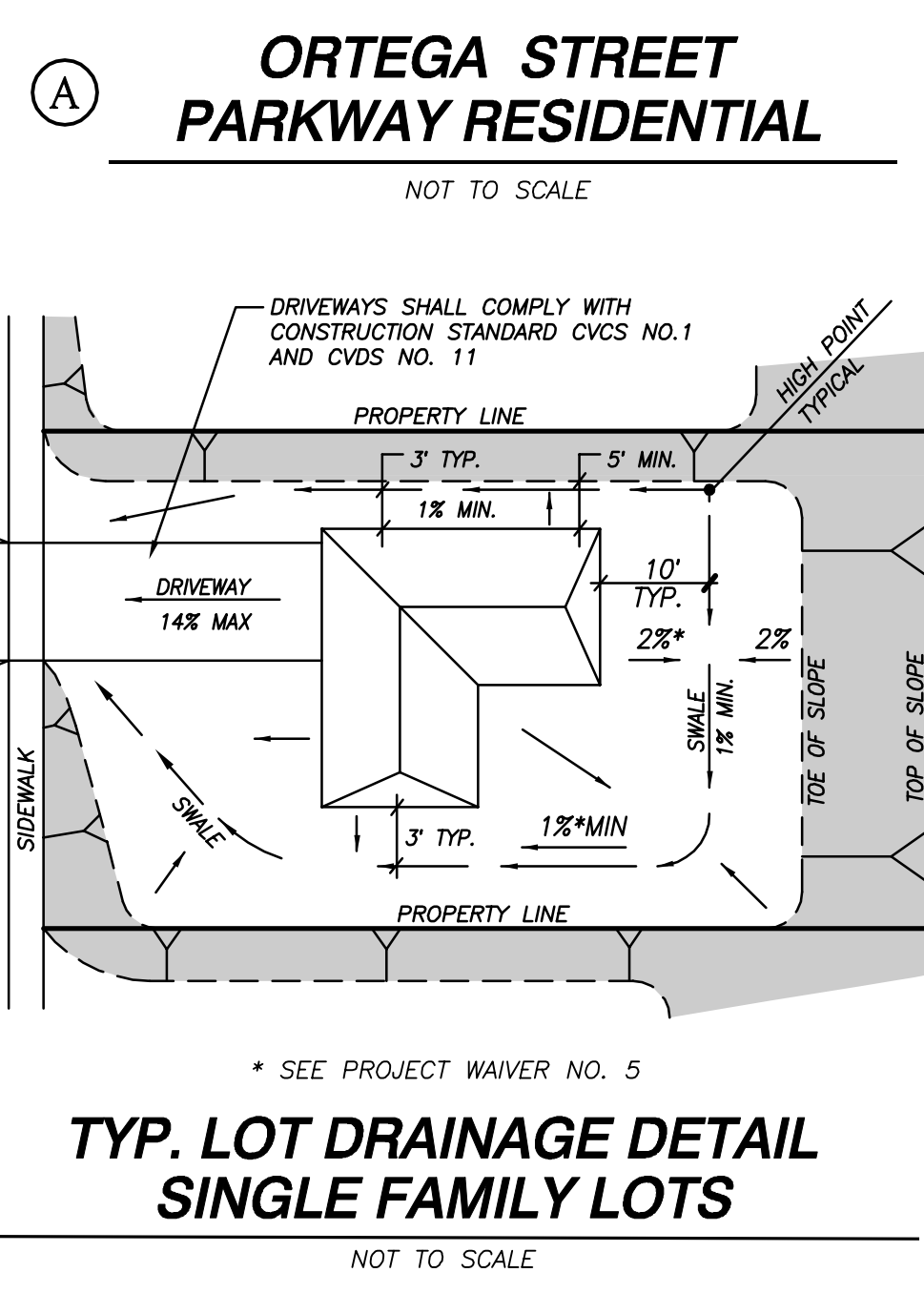
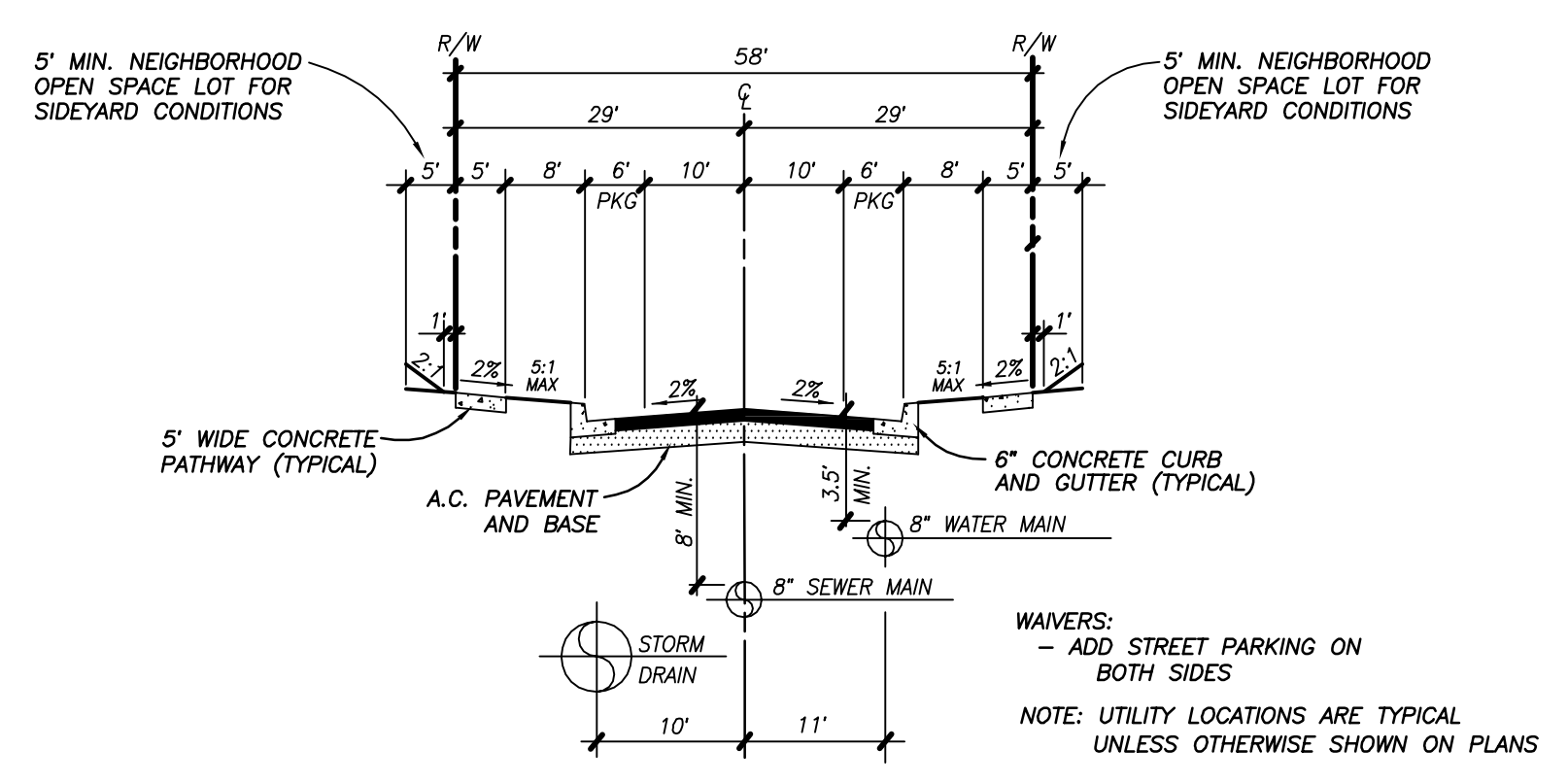
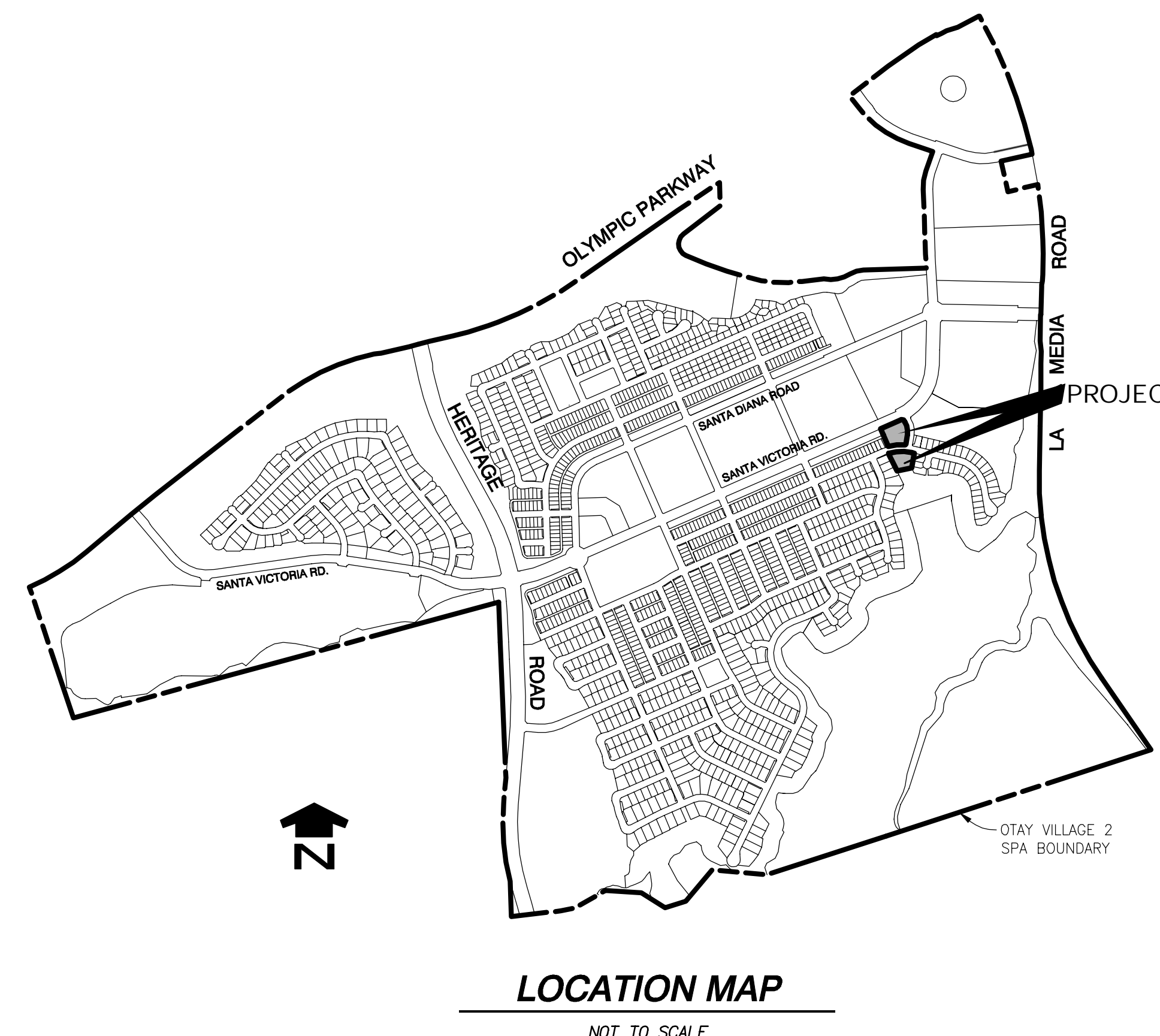
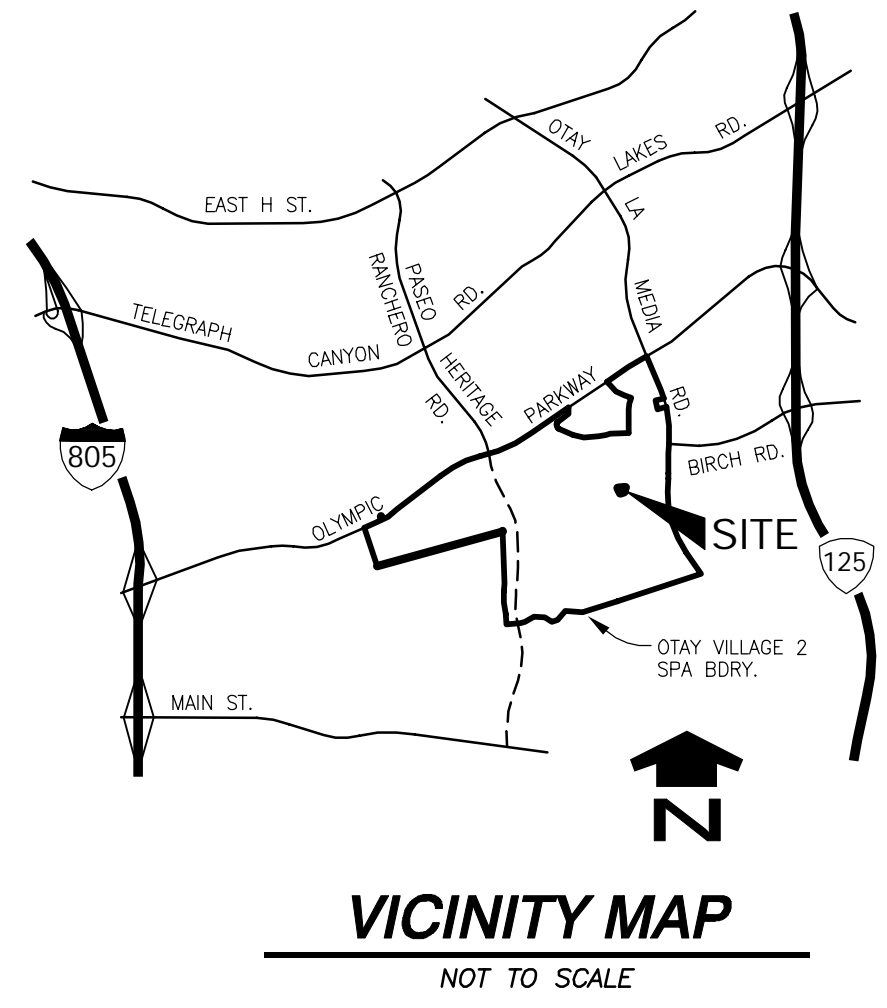

PRELIMINARY LOTTING STUDY OTAY RANCH VILLAGE 2 R-15b & R-31

PREPARED BY:	NO. REVISIONS	DATE	BY
<b>HUNSAKER &amp; ASSOCIATES</b> SAN DIEGO, INC. 9707 Maples Street San Diego, CA 92121 SURVEYING: PH858558-4500 - FX858558-4444	1	06/25/12	H&A
	2	REV. PER CITY COMMENTS	03/14/13 H&A
	3	REV. PER CITY COM. & ADD R-31	03/07/14 H&A
	4	REV. PER CITY COMMENTS	07/23/14 H&A
	5	REV. WEST FUTURE LOTS	09/12/14 H&A
	6		
	7		
	8		

TENTATIVE MAP  
**OTAY RANCH VILLAGE 2 R-15b & R-31**  
CITY OF CHULA VISTA, CALIFORNIA

SHEET **1** OF **1**